

1 Core Overview

The Character LCD Core displays characters on the Liquid Crystal Display (LCD) on Altera's DE2 board.

2 Functional Description

The Character LCD Core sends characters to the LCD according to the Character Generator ROM Pattern of the LCD (See [LCD Datasheet](#)). The LCD on the DE2 board supports at most 16×2 characters (16 characters per line, 2 lines maximum).

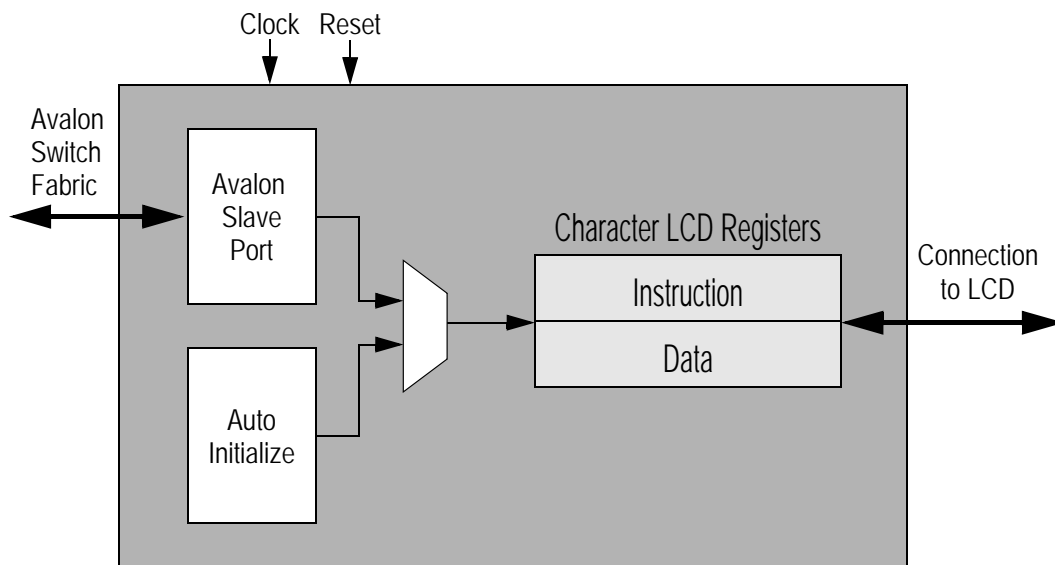

Figure 1. Block Diagram for Character LCD Core

The Character LCD Core initializes the LCD Controller upon reset and communicates with it after that. It provides a memory-mapped interface for user to control and write to the LCD screen by writing to certain memory addresses.

The LCD Core supports a clock frequency of 50 MHz, which is readily available on the DE2/DE1 boards.

3 Instantiating the Core in SOPC Builder

The Character LCD Core is a component that can be instantiated by using the SOPC Builder.

3.1 Configuration Tab

The configuration tab sets the cursor type. Other settings of the Character LCD Core are automatically initialized.

3.1.1 Display Cursor

Choose the desired cursor display. The Character LCD Core supports Normal, Blinking, Both (Normal & Blinking) and No Cursor options.

4 Software Programming Model

4.1 Register Map

The device driver controls and communicates with the Character LCD Core by using registers, as shown in Table 1.

Offset in bytes	Register Name	Read/Write	31...8	7...0
0	instruction	R/W	Reserved	Control Word, which can clear the LCD and set the character location. See the LCD Datasheet for details.
4	data	R/W	Reserved	Index for the LCD Character Generator ROM. See the LCD Datasheet for details.

4.2 Software Functions

The LCD Controller is packaged with C functions accessible through SOPC Builder-generated software development kit (SDK) libraries, as listed below. These functions implement common operations that users need for the LCD Controller. When using the Altera Debug Client, these functions are automatically provided for use in a C-language application program. To use the functions, the C code must include the statement:

```
#include "alt_up_character_lcd.h"
```

The following functions are provided:

4.2.1 void alt_up_character_lcd_init ()

Initialize the LCD by clearing its display.

4.2.2 int alt_up_character_lcd_write (const char * *ptr*, unsigned *len*)

Write the characters in the buffer pointed to by *ptr* to the LCD, starting from where the current cursor points to.

Parameters:

ptr – the pointer to the char buffer

len – the length of the char buffer

Returns:

0 for success

4.2.3 int alt_up_character_lcd_shift_cursor (int *x_right_shift_offset*)

Shift the cursor to left or right.

Parameters:

x_right_shift_offset – the number of spaces to shift to the right. If the offset is negative, then the cursor shifts to the left.

Returns:

0 for success

4.2.4 int alt_up_character_lcd_set_cursor_pos (unsigned *x_pos*, unsigned *y_pos*)

Set the cursor position.

Parameters:

x_pos – x coordinate (0 to 15, from left to right)

y_pos – y coordinate (1 for the first row, 2 for the second row)

Returns:

0 for success

4.2.5 int alt_up_character_lcd_erase_pos (unsigned *x_pos*, unsigned *y_pos*)

Erase the character at the specified coordinate.

Parameters:

x_pos – x coordinate (0 to 15, from left to right)

y_pos – y coordinate (1 for the first row, 2 for the second row)

Returns:

0 for success

